

BKT Extraction Unit

The BOFA Pure Beauty BKT mobile fume extraction and filtration system has been purposely designed to capture and remove the harmful fumes generated when carrying out a Brazilian Keratin hair Treatment.

The health risks associated with BKT treatments have been well documented in the media. Until now a practical solution has not been available. The Pure Beauty BKT offers a solution that requires no fixed installation, is cost effective and allows the stylist to work freely yet safely.

STANDARD FEATURES:

- Low noise level
- Fully portable
- Deep bed chemical filter
- Effective receptor capture hood

OPTIONAL FEATURE:

- VOC Sensing (Volatile Organic Compound)

The complete mobile extraction solution for Brazilian Keratin Hair Treatment.



Deep bed chemical filter



PART NUMBERS			
Model - Powder Coated	Part No.	VOC Monitoring	
Pure Beauty BKT	230V	E2342A	A2003

REPLACEMENT FILTER	
Model	Chemical Filter
Pure Beauty BKT	A1030256

TECHNICAL DATA	
	CE
Dimensions (hxwx d)	552 x 428 x 737
Cabinet Construction	Powder coated mild steel
Blower	1.1kw
Airflow	380m ³ hr
Electronics	230v 1ph 50/60Hz FLC 8 Amps
Noise Level	< 65dBA*
Weight	70kg

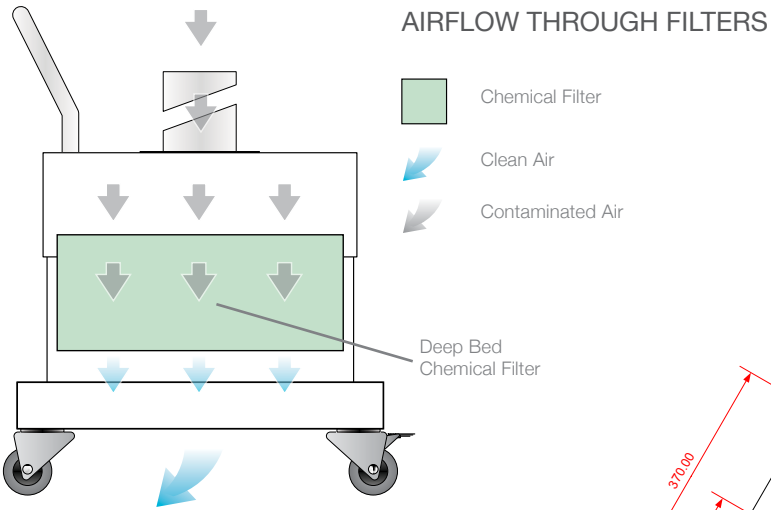

TECHNICAL SPECIFICATION

- | | |
|------------------------------|-----------------------|
| 1 Extractor Arm - 100mm | 7 Exhaust Outlet |
| 2 On / Off Switch | 8 Motor Cooling Inlet |
| 3 Handle | 9 Handle |
| 4 Power Inlet | 10 Hood |
| 5 Filter Housing Latch | 11 Double Castors |
| 6 100mm Arm Inlet Connection | 12 Silencer |

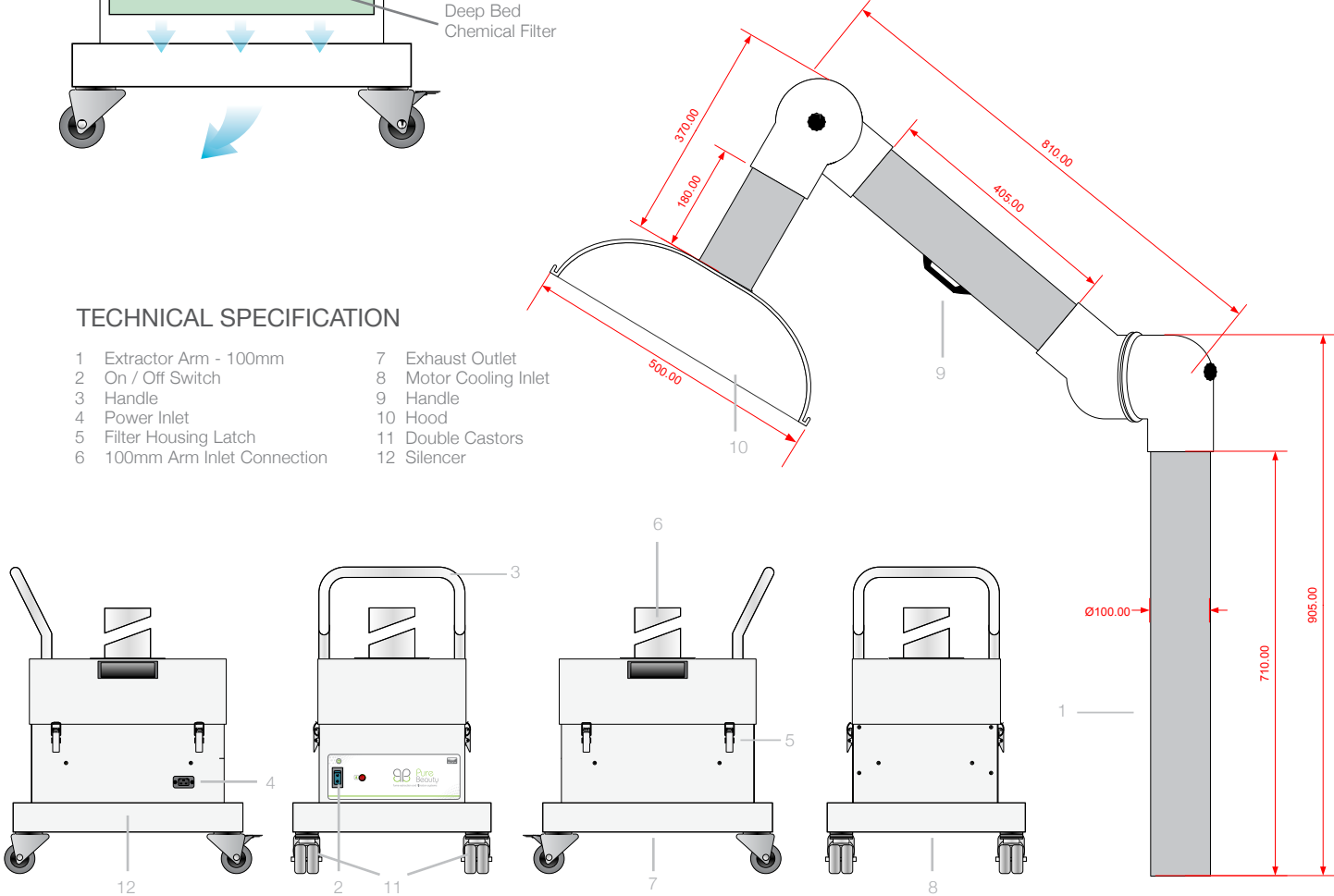

* At typical operating speed.

BOFA INTERNATIONAL LTD

Tel: +44 (0) 1202 699 444 Fax: +44 (0) 1202 699 446 Email: sales@bofa.co.uk Web: www.bofa.co.uk

BOFA AMERICAS, INC

Tel: (618) 635 4465 Fax: (866) 707 2632 Email: sales@bofaamericas.com Web: www.bofaamericas.com

